

# PROBOIL.3.0

## User Guide

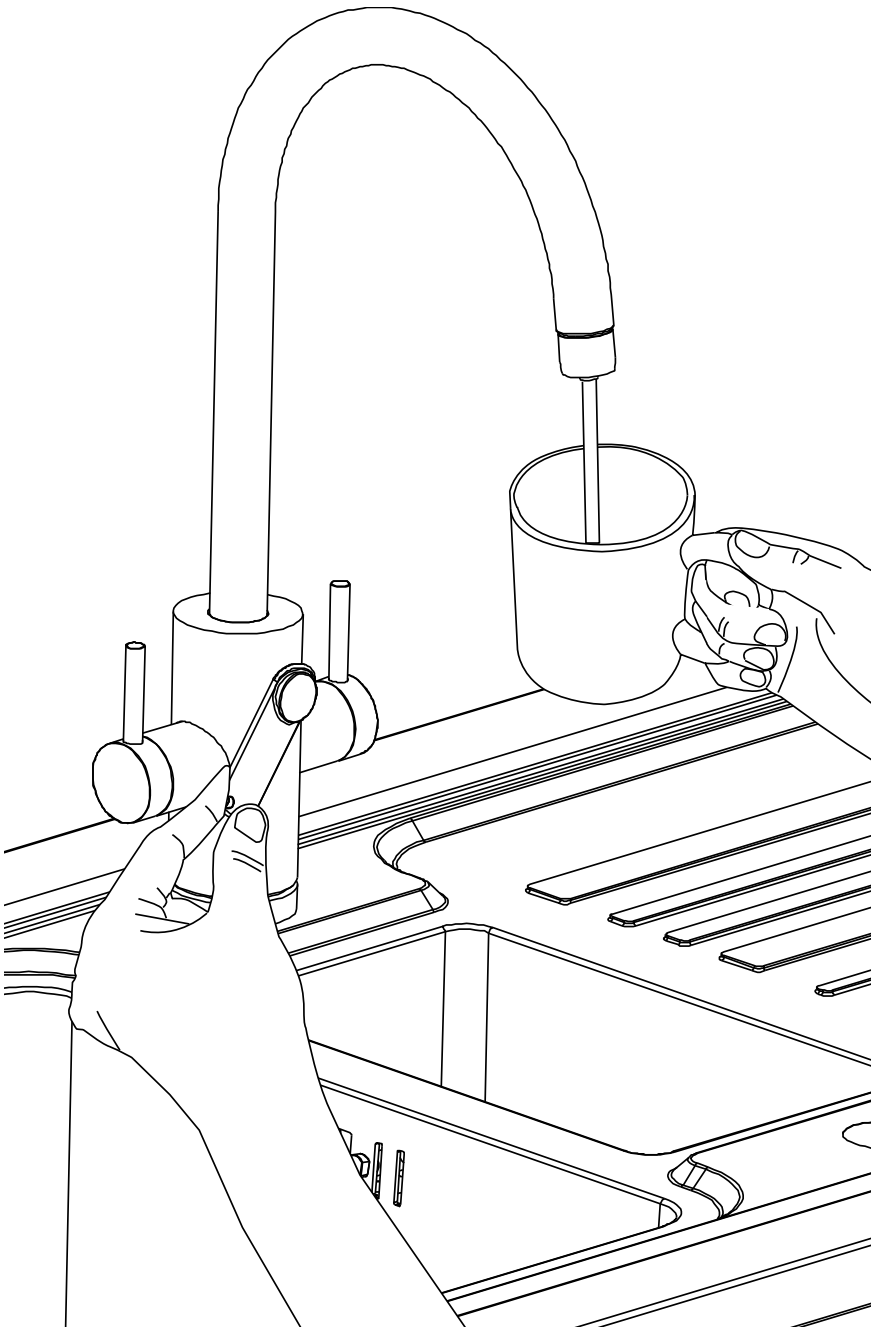

[www.proboil.co.uk](http://www.proboil.co.uk)

See top of boiler for contact details

**ⓘ Please read these instructions carefully and retain for future reference.**

We have a policy of continued product and quality development and improvement, accordingly we reserve the right to amend the specification at any time, all errors and omissions excepted.

## Important safety and usage considerations:

 **WARNING:** This appliance can be used by children aged from 8 years and above and persons with reduced physical, sensory or mental capabilities or lack of experience and knowledge if they have been given supervision or instruction concerning use of the appliance in a safe way and have understand the hazards involved. Children shall not play with the appliance. Cleaning and user maintenance shall not be made by children without supervision.

 **WARNING:** This appliance must only be used for heating water.

 **WARNING:** Do not use a water or steam jet to clean the PROBOIL appliance.

 **WARNING:** Servicing and maintenance of this product must be carried out by persons having knowledge and practical experience of the appliance, in particular as far as safety and hygiene are concerned. The PROBOIL system contains no user serviceable parts and should only ever be serviced by the recommended service agent.

 **WARNING:** This product should only be installed into an internal domestic environment with an ambient temperature of 10-40°. If the unit is accidentally left filled in an unheated environment for a prolonged period do not switch on if there is a possibility that the water inside is frozen, it must defrost naturally.

 **WARNING:** All surfaces especially those made from metal may become hot whilst in operation. Use caution when touching these surfaces. Inform all users that the surfaces may become hot.

 **WARNING:** Do not open drain cocks or other emptying devices until the pressure has been reduced to approximately atmospheric pressure and the water in the tank has cooled to a safe temperature.

 **WARNING:** Do not use this appliance if you suspect it or any of its hoses are damaged in any way or is performing differently from how you would expect. Never use any appliance with a damaged mains power lead. You should immediately disconnect the power and contact the service agent noted on the top of the boiler.

### Day to day considerations:

 If the product is going to remain unused and unattended for a prolonged period, the boiler should be switched off. If the period is extended beyond a typical holiday then we recommend the boiler is also drained. As with any appliance, the water supplies should also be isolated.

 Use of any cleaners with acids, abrasives, alkaline, and organic solvents can result in deterioration of the components and will void the warranty.

 Whilst we do not expect you to encounter any leaks, you should regularly inspect the system for leaks. If there are signs of water damage, you should immediately remove the unit from service and contact the service agent.

 Cleaning and user maintenance shall not be performed by children without supervision.

### Do not modify the product supplied:

 Do not add to, exchange or modify any component of the boiler or mixer tap. The spout exit or any part of the system must not include any additional third party adaptors or connections that will add resistance to the system.

 This appliance is intended to be permanently connected to the water mains.

 We only warrant the original filter type supplied with your boiler, which is formulated specifically for the PROBOIL product. If the filter is removed or exchanged for an alternate model it may have a detrimental effect to your system and accordingly will invalidate your warranty. If you have specific or unusual incoming water conditions please contact the service number on the boiler for further advice.

 The boiler and mixer tap are not designed to work with any other combination of appliances other than as shown within this guide.

### Sensible fire safety precautions:

 Do not store or use petrol or other flammable rags, paper aerosols vapours and liquids in the vicinity of this or any other appliance. The air gaps as described earlier in this guide should be respected and not blocked at any time. Do not block the ventilation slots in the base, side or rear of the boiler unit.

 Do not obstruct the ventilation slots in the base, side and rear of the product.

 In order to avoid a hazard due to inadvertent resetting of the thermal cut-out, this appliance must not be supplied through an external switching device, such as a timer, or connected to a circuit that is regularly switched on and off by the utility.

 Do use any water jet or steam near this appliance.

 This appliance should have at least 10mm clearance at both sides and back. Where this appliance is to be positioned in close proximity to a wall, partitions, kitchen furniture, decorative finishes, etc., it is recommended that they be made of non-combustible material, or if not, that they shall be clad with a suitable non-combustible heat-insulating material, and that the closest attention be paid to fire prevention regulations.

 Install the unit on a heat-resistant surface. Make sure that the installation surface is firm and level.

 For safety regulations the plug or means of disconnection must always be accessible after installation.

 The mounting bracket (A3) must be used to prevent the accidental tipping of the appliance

## Descaling the PROBOIL system:

The filter system provided with PROBOIL will help to prevent of the calcification (scaling) of the boiler. However it will be required from time to time that the PROBOIL will need to be descaled, drained and refilled to ensure the maximum energy efficiency and service life from the product especially in hard water areas. Descaling solutions can be obtained by contacting the service agent shown on the label on top of the boiler.

Ensuring that the filter system is set up correctly and replaced as required will reduce the frequency of descaling required.

If you are regularly needing to descale the PROBOIL system then you either need to replace the filter more frequently or check the bypass setup of the filter system.



**IRRITANT**

CAUTION: Harmful if swallowed. Irritating to eyes and skin. KEEP OUT OF REACH OF CHILDREN. Avoid contact with skin and eyes. In case of contact with eyes, rinse immediately with plenty of water and seek medical advice. After contact with skin, wash immediately with plenty of water. If swallowed, seek medical advice immediately and show this container or label.

MSDS Available. Ingredients: Sulfamic Acid. Country of origin USA. [www.proboil.co.uk](http://www.proboil.co.uk) for more information.



Scan here to link to a video demonstration

 The descaling chemical is acidic and should only be used and handled as indicated, care should be taken not to ingest, expose to skin, clothing or decorative surfaces.

 Take care when touching all surfaces and when disconnecting or connecting hoses they may be hot and or generate steam, you must use personal protective wear to prevent accidental scalding.

1. If required, adjust the PROBOIL temperature to 80°C (see [user guide](#) for more details). **Only** If the boiler is already set to a temperature higher than 80°C then dispense at least 1 litre from the boiler using the 'Hotkey' key fob, now allow the boiler to fully fill and heat. Once completed then switch off the PROBOIL at the front control panel (see user guide / [powering down](#) for more details).
2. Wait until the flexible connector (B9) has cooled to a safe touch temperature, this may take some time.
3.  Ensure the flexible connector (B9) is cool to the touch before proceeding, afterwards unscrew by hand the flexible connector (B9) from the top of the boiler. **Wear suitable gloves to ensure your safety.**
4. If the boiler is only lightly calcified (scaled) use 1 x 200ml descaler liquid bottle, if the boiler is heavily calcified use 2 x 200ml descaler bottles, if you are unsure we recommend you use 2 x 200ml bottles.

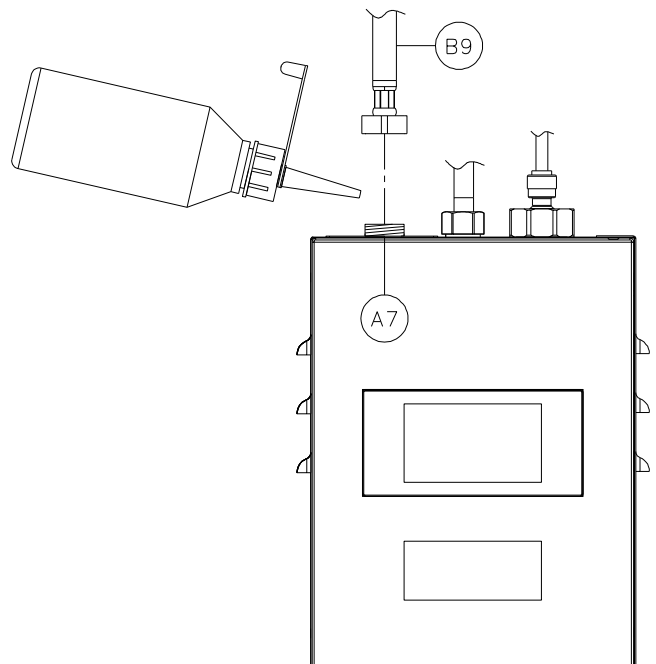



5. Shake the bottle gently then carefully cut the top of the bottle nozzle open with a pair of scissors.
6. Carefully and slowly empty the contents of the descaler bottle into the boiler vent (A7), if access for the bottle nozzle is difficult a plastic funnel can be used to help.

 Take care during this step as steam is expected to exit the vent (A7) as the descale solution is added.

7. Take note of the time and wait for **no longer than 30 minutes maximum** for the descaler liquid to work. It is normal for an odour to be present during this time.
8. Firmly reattach the flexible connector (B9) to the boiler vent (A7). **Wear suitable gloves to ensure your safety.**
9. Switch on the PROBOIL at the front control panel (see user guide for more details).
10. Dispense the entire contents of the boiler using the Hotkey, before immediately switching off the PROBOIL at the front control panel (see [using the product](#) for more details).
11. Drain the remaining water from the tank (see [draining section](#) of the user guide for more details).
12. Close the drain (A12).
13. Switch on the PROBOIL at the front control panel (see user guide for more details).
14. Allow the PROBOIL to fully fill and heat to back to a maximum temperature of 80°C this process will take a minimum of 20 minutes, again it is normal for an odour to be present during this time.
15. Repeat steps 10-12 draining the boiler entirely.
16. Disconnect and stow the drain pipe (A14) & connector (A13) securely replace the drain cover (A11) and screw (A10).
17. If required, adjust the temperature to your previous preference (see [user guide](#) for more details).

 Should any taste or odour persist in normal use after flushing the unit twice, repeat the flushing procedure as described in steps 10 to 14 until it subsides.

 PROBOIL descaling agent has been formulated and tested specifically for your appliance, no alternative descaling agents should be used, it may damage you appliance and invalidate your warranty. For PROBOIL descaler sales please contact the service number on the top of the boiler.

 In the event that the boiler is heavily scaled and following the above steps did not remove all the scale, repeat the complete descaling procedure. If further descaling does not clear any descale warning on the PROBOIL, please contact the service agent using the labelled contact details on top of the boiler.

 Each time the drain valve is used, you should always carefully check that after use the drain valve is fully closed, and not dripping, any leak from the drain may cause damage to the equipment or surroundings. Take care not to move the drain valve lever (A12) when stowing the adaptor (A13) and drain hose (A14).

 If the boiler was not perfectly level when it was installed, a small amount of water will remain in the tank. In this instance it may be necessary to loosen screw (A4 OR A5) and tilt the boiler slightly to drain any trapped remnants. Once completed, remember to replace the fixing bracket safety screw.

## Draining the PROBOIL system:

It might be necessary from time to time to drain the PROBOIL system during servicing and descaling. Please follow the procedure below or watch the video, which can be found via the QR code.



Scan here to link to a video demonstration.

The 'Hotkey' key fob can be used to drain most of the water from the tank, but to fully empty the tank, the drain valve (A12) must be used.

 The water in the PROBOIL tank may be up to 98°C and as such represents a scalding risk if handled without due care. We recommend that the boiler is switched off on the front panel before draining any stored water. It will take approximately 8 hours (overnight) for a full 98°C tank to naturally cool to a touch safe temperature of 46°C. Do not open the drain valve until the hot water is at atmospheric pressure. Should you need to drain the boiler without allowing it too naturally cool, then you must take adequate care and use personal protective wear to prevent accidental scalding from hot water, surfaces and steam.

- 1) Use the Hotkey to drain hot water from the tank until no more water can be dispensed.
- 2) Ensure the boiler (A1) is turned off at the front control panel and allowed to cool down (see [powering down](#) section of user guide for more details).

- 3) Remove the slotted screw (A10) from the access plate (A11) at the bottom of the boiler front panel, place it somewhere safe so it does not get lost accidentally.

- 4) Place a washing up bowl or bucket on the floor below the level of the drain. **Note:** a 5 litre vessel capable of holding hot fluid safely is required.

- 5) Connect the adaptor (A13) and drain hose (A14) to the valve and hand tighten.

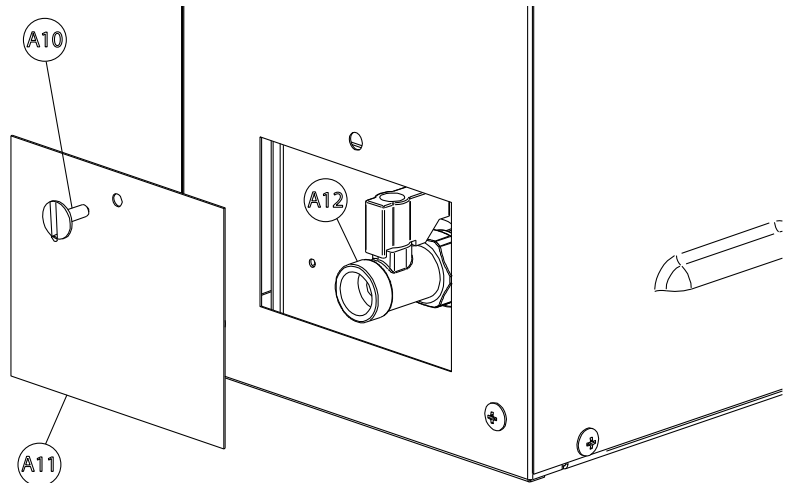

- 6) Turn lever (A12) to open valve and allow water to drain into washing up bowl or bucket.

- 7) Once all the water has drained from the unit close the drain valve (A12).

- 8) Gently shake the drain hose (A14) and coil.

- 9) Place coiled drain hose (A14) into the compartment and replace cover (A11) using the hand screw (A10).

- 10) Safely and carefully dispose of the waste water.

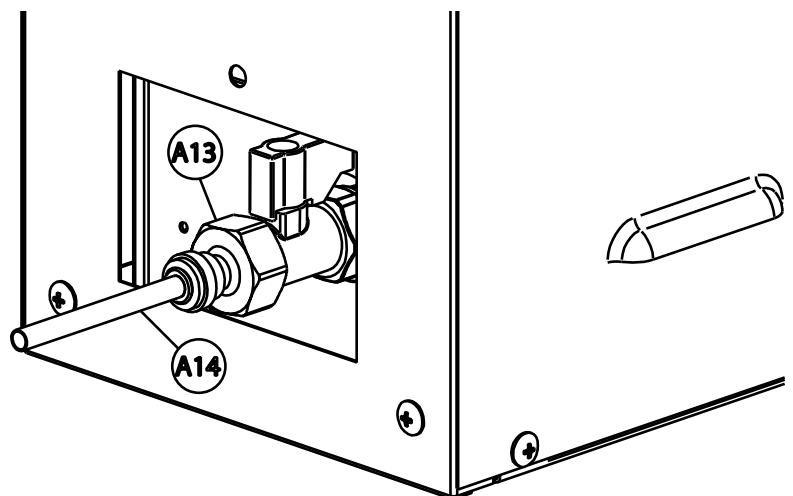

## Using the product:

Thank you for choosing this product. By reading this guide you will ensure that the product is used safely and will give its best performance. Throughout this guide, symbols are used to highlight key points or safety considerations.



= an information point or tip.



= a technical or safety consideration or warning.



= a service, maintenance or care consideration.



### Your tap can dispense 4 types of water:

- 1) **Cold (unfiltered) water directly from mains supply** - This is delivered when the right tap handle is pulled forwards.
- 2) **Cold (filtered) water** - This is delivered when the right tap handle is pushed backwards. We recommend “flushing” the filtered water on each use to ensure cold and fresh water is delivered:
  - a. Additionally, if the tap has not been used for 1 week you should flush 2 litres.
  - b. Or if the tap has not been used for 4 weeks you should flush 10 litres.
- 3) **Hot (domestic) water** - This is delivered when the left tap handle is pulled forwards.
- 4) **Hot (boiled & filtered) water** - This is delivered when the ‘Hotkey’ key fob is moved close to, or rested on the front of the tap below the spout near the indicator symbol.

 **98°C water,** we have taken great care to deliver a product with many built in safety features but you will also need to take due care when dispensing near boiling water to avoid accidental scalding.

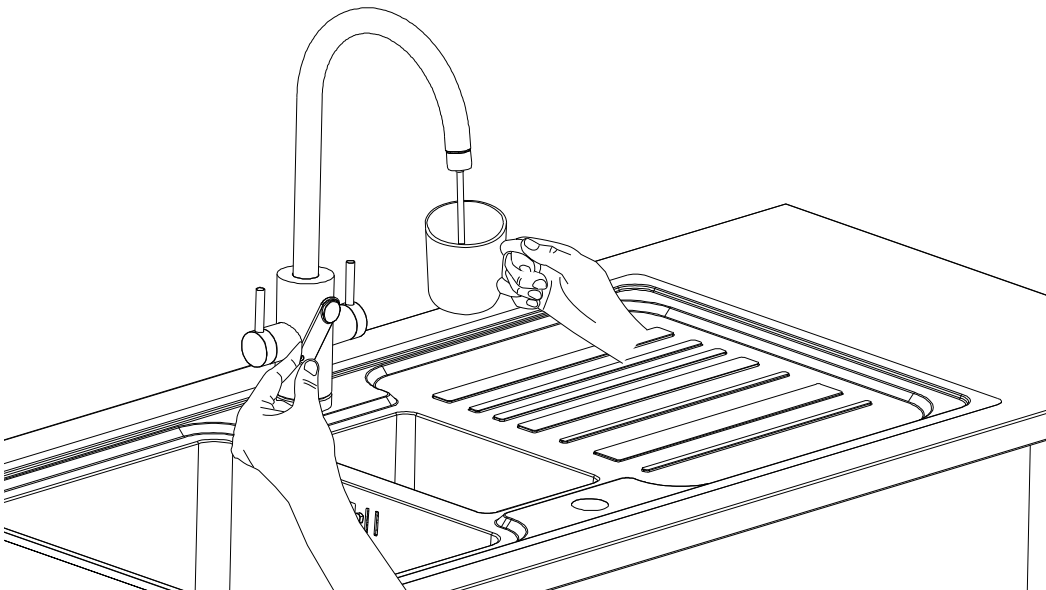

When dispensing, hold the Hotkey close to the ‘cup’ symbol on the centre front of the tap. The boiler will dispense water. When the Hotkey is moved away, it will automatically stop dispensing hot water.

**Important:** To reduce the risk of splashing, avoid holding the vessel that you are filling too far away from the spout exit.

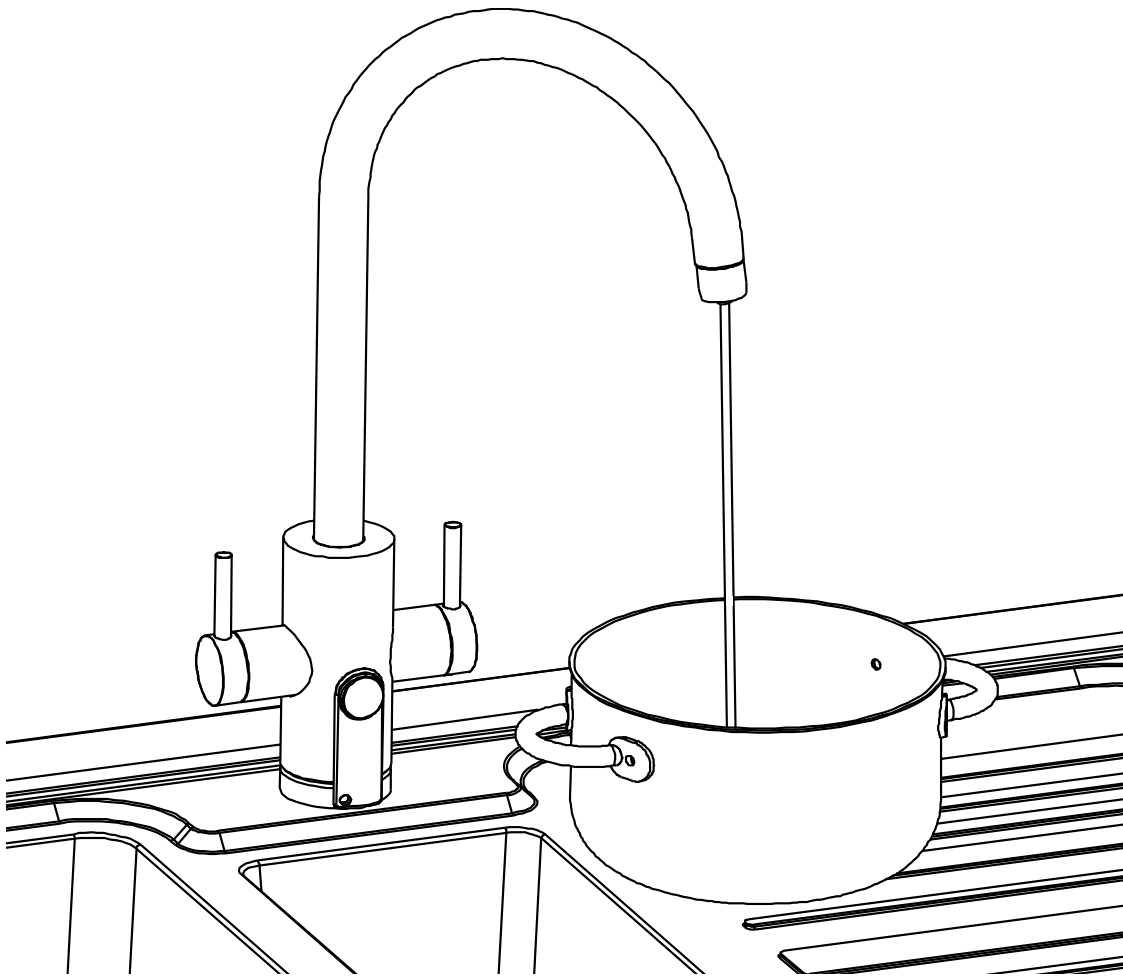

**i** If two hands are needed (to hold a pan for example), the Hotkey can be leaned against the front of the tap instead. If the pan is particularly heavy, first swivel the spout and then rest the pan on the drainer.

**!** When dispensing hot water always be mindful to keep your hands and arms from being under the spout exit. Even though it is thermally insulated, you should avoid touching the very end of the spout, especially immediately after dispensing hot water.

**i** This product has a unique safety system by using the 'Hotkey' key fob to dispense the near boiling water. If you want to prevent the accidental use of the near boiling water function only, then store the Hotkey away from the tap. The Hotkey is magnetic to allow you to 'stick' it in out of reach places (such as the fridge or the cooker hood). With the Hotkey away from the tap, it can only be used as a conventional tap without the hot water function.



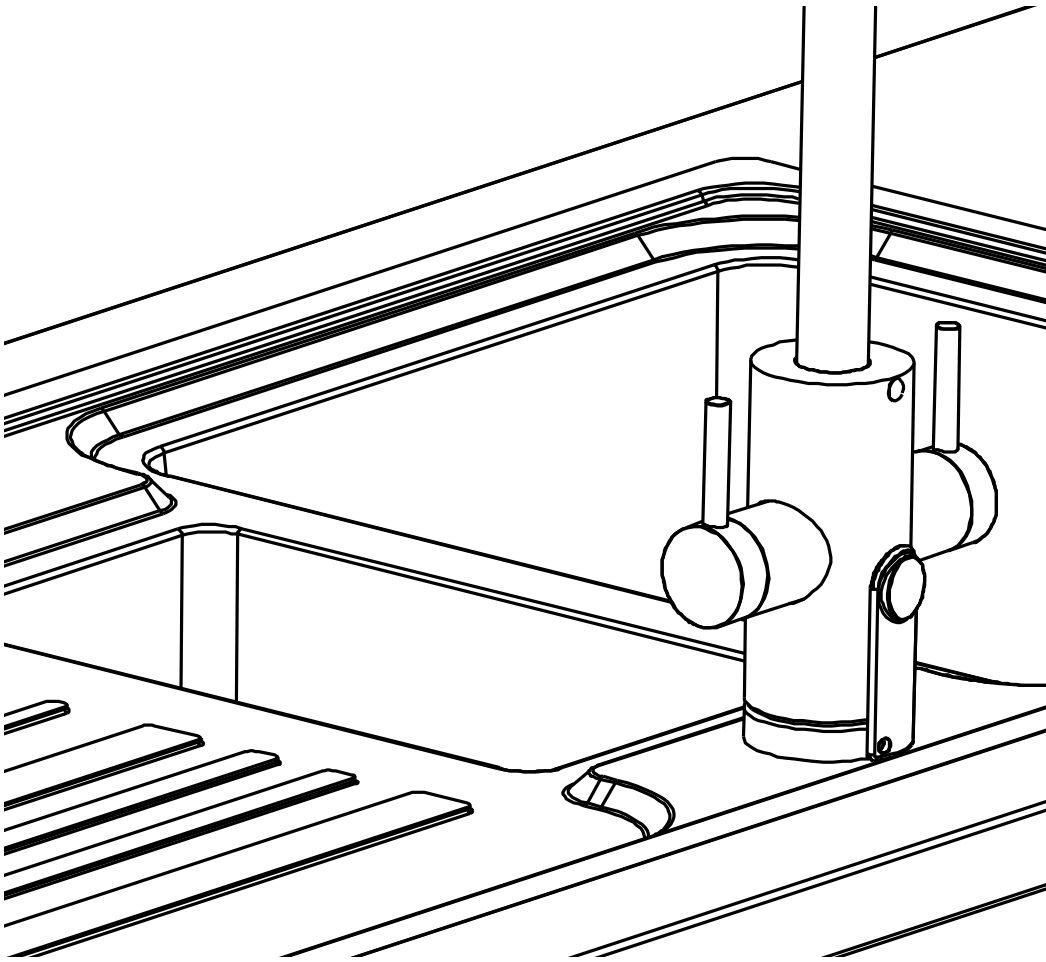

**i** If the tap can only be used by competent adults, then the Hotkey can be 'stuck' to the rear of the tap body (as shown) when not in use for more convenient access.



## Magnetic fields:

The 'Hotkey' key fob houses a strong magnet used to sense its proximity to the mixertap and also for convenience when storing the Hotkey. Any customers with a pacemaker should not place the Hotkey within 5 inches (100mm) of such devices.

All magnets can damage electronic devices and bank cards so they should be stored away from each other.

## User display and interface:

The product has a simple 4 button interface. The display will indicate the status of the boiler and the estimated remaining filter life so you know when to replace the filter. The display has a clear film cover which must be removed.

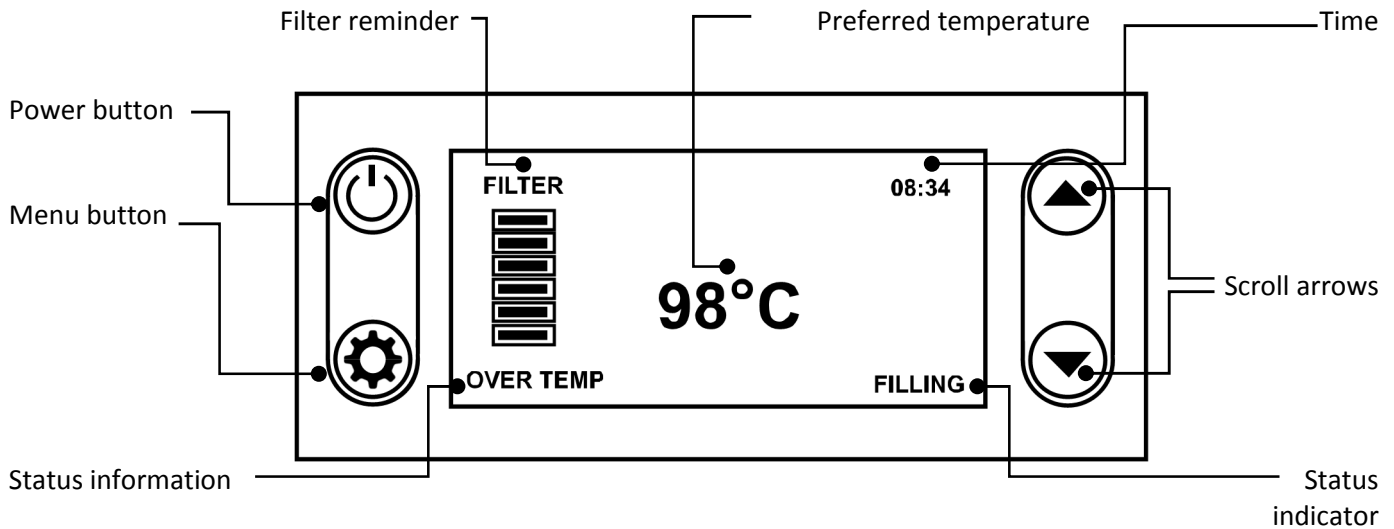

To exit a menu at any time, press the 'POWER' button.

### Status indicator messages:

<b>Filling</b>	The boiler is filling with fresh cold water to replace the hot water just used.
<b>Heating</b>	The boiler is heating the fresh cold water to the preselected temperature.
<b>Ready (intermittent)</b>	The unit is at the preselected temperature but the tank is not full. A partial dispense is still available though.
<b>Ready (constant)</b>	The unit is full of hot water, up to the preselected temperature and ready to use. A full dispense is available.
<b>Eco</b>	The boiler is in energy saving mode and the water tank temperature has been reduced to 80°C to save energy.

### Status information messages:

<b>Water Filter Management</b>	Filter life reminder period has expired, check if filter needs replacing.
<b>Temperature Sensor Faults</b>	Temperature sensor self-diagnostic error, contact service agent on top of boiler.
<b>Not Heating Fault</b>	Heating self-diagnostic error, contact service agent on top of boiler.
<b>No water</b>	No water supply self-diagnostic error, confirm water supply is on, if problem persists contact service agent on top of boiler.
<b>PCB Fault</b>	PCB self-diagnostic error, contact service agent on top of boiler.
<b>Descale stage 1</b>	Product must be descaled now otherwise your warranty at risk, contact service agent on top of boiler for descaling solution, only use PROBOIL descaler.
<b>Descale stage 2</b>	Descale delayed for 4 days, any resulting service request is now chargeable.
<b>Descale stage 3</b>	Your PROBOIL has self-shut down to prevent further damage due to limescale. The product must be descaled before further use is permitted.

## Setting the water temperature:

1. The current preferred temperature is displayed on the centre of the screen.
2. Once the boiler reaches this temperature you will see a steady 'READY' status appear on the screen.

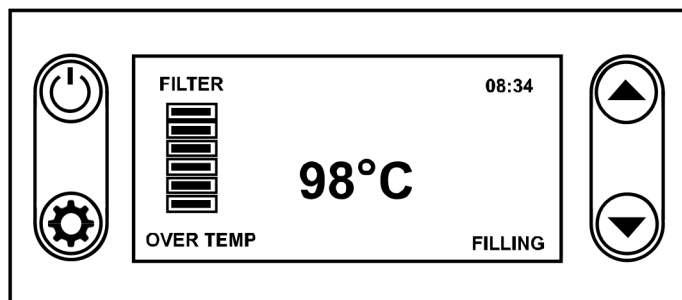

The default temperature is 98°C but you can set the desired temperature anywhere between 80-98°C to suit your personal preference.

**i** The maximum temperature of 98°C is based on the UK maximum legal requirement for stored water.

3. Press and hold the UP or DOWN scroll arrows to adjust to the desired temperature.
4. If the temperature of the water is below your preferred set temperature the boiler will show a 'HEATING' message.
5. If the temperature of the water in the boiler is above your preferred set temperature, the boiler will not reach the desired lower temperature until the excess heat has been naturally lost. This will happen faster if some of the stored hot water is dispensed and therefore replaced with cold.

## Suggested temperatures for teas:

Tea type	green	oolong	black	herbal
Temperature (°C)	75-80	80-85	98	98
Steeping time (minutes)	1-2	2-3	2-3	3-6

Note: it is normal as with any hot water dispenser that thermal energy is lost by the time it is dispensed into the cup. Therefore, the temperature in the cup is not representative of the tank temperature.

**In order to reach the highest 'in cup' temperatures you should first dispense & dispose a small amount of water to preheat both the system and your cup.**

## Setting the clock:

1. By pressing the 'MENU' button, the SET CLOCK will be highlighted.
2. Press 'MENU' to enter the SET CLOCK menu. The time will be displayed and the hour values will be flashing.
3. Use the scroll arrows to select the correct value and press MENU. The minute values will now be flashing.
4. Use the scroll arrows again to select the correct values.
5. To store the new set time press the 'MENU' button. This will also take you back to the SET UP menu.
6. To exit the SET UP menu press the 'POWER' button.

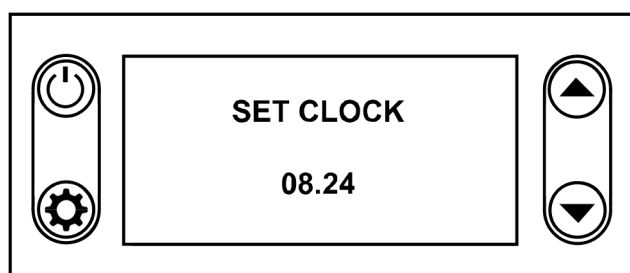
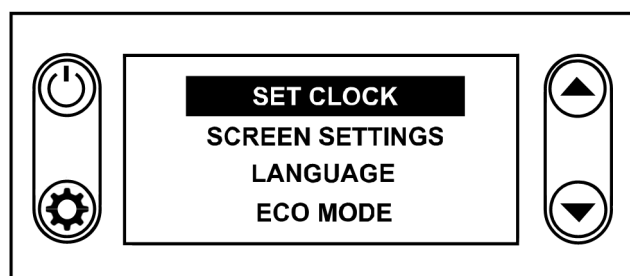

### Changing the screen settings:

1. Press 'MENU' and navigate down using the scroll arrows until SCREEN SETTINGS is highlighted.
2. For the backlight brightness, the values will flash. Use the scroll arrows to choose the backlight brightness (between 1-5).
3. Once satisfied with the new backlight brightness value, hold 'MENU' to store.
4. Now the contrast values will flash. Repeat for the contrast.
5. Hold 'MENU' to store and to exit.

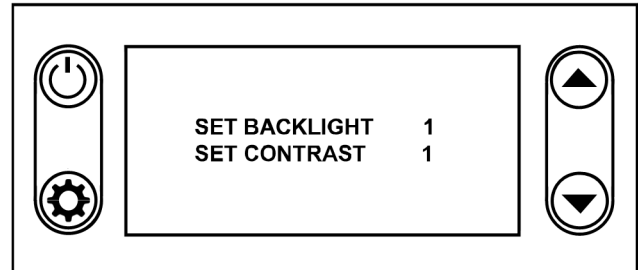
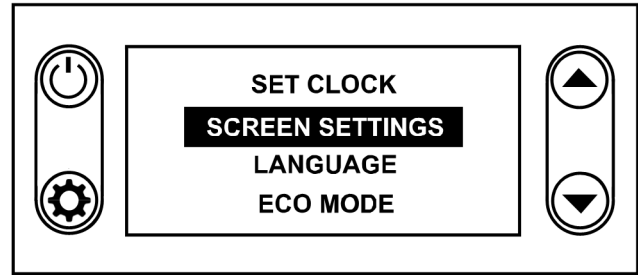

### Changing the language:

1. The default language is English but can be changed to one of many languages to suit your needs.
2. Press 'MENU' and navigate down using the scroll arrows until LANGUAGE is highlighted. Then the press 'MENU'.
3. Scroll down to the preferred language.
4. Hold 'MENU' to store and exit.

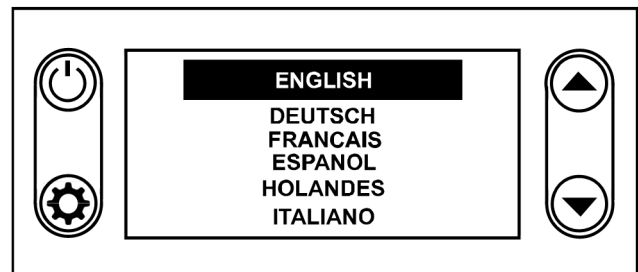
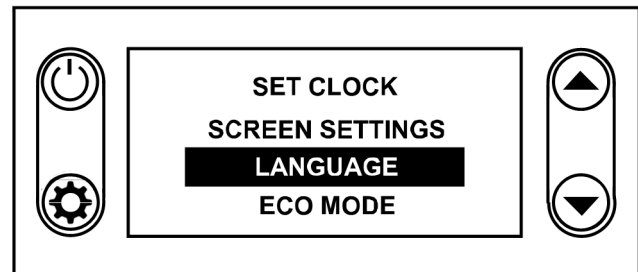

### Child lock:

1. Press and hold the 'MENU' and the UP scroll arrow for 3 seconds.
2. The Child Lock function will activate/deactivate.
3. When the Child Lock function is active, only the 'MENU' and the UP scroll arrow are active to deactivate the child lock function.
4. The lock logo will blink on the screen for a couple of seconds when you press any button.
5. To turn off the Child Lock, follow the same process as above.

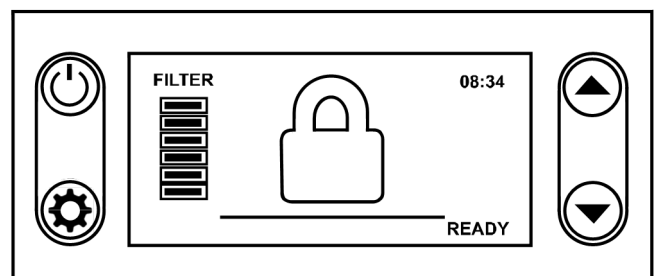

**Note:** Whilst in 'Child Lock' mode, the boiler will still dispense but the boiler settings cannot be altered.

## Setting the Eco mode:

The boiler features 3 levels of energy saving:

- ECO MODE (ON)** After two hours of inactivity the boiler automatically enters Eco mode.
- ECO MODE (TIMED)** The boiler enters Eco mode between the stated times.  
To set the Eco mode timer, simply scroll down to 'ON' to set the desired time. Once you are happy with the time that has been set, press the menu button to confirm this.  
This will then take you to 'OFF', where you can then set the time that you want the Eco mode to finish.
- ECO MODE (OFF)** The boiler does not enter Eco mode.  
This is the least energy efficient setting.

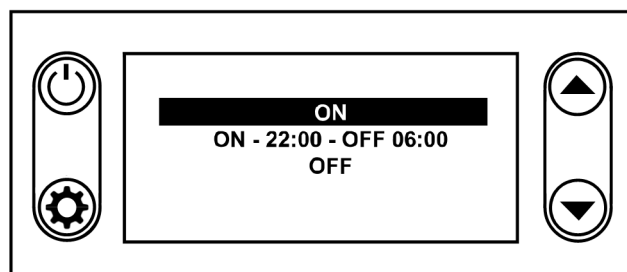
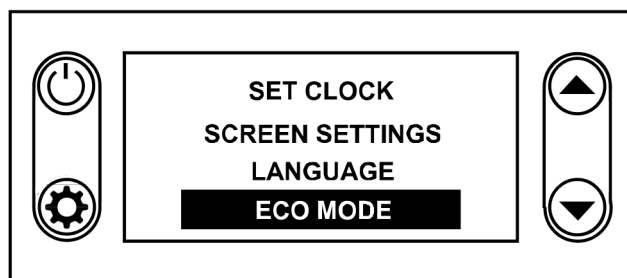

## Shutting down:

1. To shut down the product, the 'POWER' button should be held when on the normal operation screen for 10 seconds.
2. The shutdown screen will appear and using the scroll buttons, 'Yes' should be selected by pressing 'MENU'.
3. The unit will then shutdown.

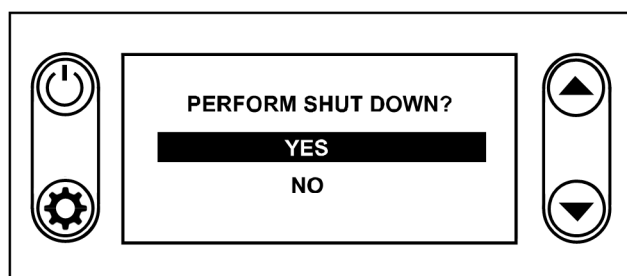

## First fill cycle process:

 Once your product has been installed and set up, complete two full fill and empty cycles, this should have been performed by your installer, but if you are unsure we recommend these steps are followed regardless. These steps will allow any remains of water from factory testing to be removed.

1. Allow the unit to completely fill until the status screen shows a steady state "ready".
2. Using your Hotkey, empty one full tank of water from the unit, through the tap, until the water stops.
3. Repeat steps 1-2 then your appliance is ready for use.

## The requirement for checking the filter life:

The premium filter used with the PROBOIL system is designed for three functions:

- 1) A coarse pre-filtration and fine 5 micron post filtration membrane this is designed to reduce dirt, clay, rust, debris and sediment.
- 2) An activated carbon filter to improve the taste and odour of the drinking water, which has an approximate capacity of 1700 litres at 12.5 degrees English Clark. You will notice this element of the filter media is reaching its expiration when you begin to taste and smell the chlorination of the water.
- 3) An ION selective filter: to reduce the water hardness minerals and protect the boiler from calcification (scale) whilst retaining other useful mineral content. The capacity of this filter media is variable; please see the [“filter installation”](#) section for further details. You may not notice the filter reaching the expiration without testing your water. Accordingly, the boiler will remind you when it is time to check it. If you live in a known high scale (hard water) area and do not replace the filter frequently enough, the calcification (scale build up) will reduce the energy efficiency of you boiler and prematurely wear internal parts.

The filter life will depend greatly on many factors such as:

- Your water quality (hardness).
- Your preferred temperature setting.
- The number of people using the product.
- The usage frequency.
- The head bypass setting.
- The split usage of cold or boiled filtered water.
- The incoming water pressure and flow rate settings.

Only filtered water passing through the boiler is measured. Cold filtered water is ignored and the above variables are unknown, so the filter life indicator should only be used as a reminder to test the filter function. You may find the filter lasts longer or shorter than it suggests depending on the above factors.

## Does my filter need replacing?

Your PROBOIL displays a 'check filter reminder status bar' and has an audible beep when it reaches its estimated end point. This is based on 'average' volume and time limits and is designed to help remind you to check the filter.

Each installation has a different number of people using it, a different usage pattern and an individual water hardness "GB Clark rating". Because of this the PROBOIL will only remind you when to check the filter, you must judge for yourself if the filter needs changing or not, as no two installations are the same.

**The status bar time limit is 6 months.** This reminder is based on 19 degrees Clark (London) hardness of water and an estimated 5 litres filter use per day. The filter volume at this hardness is approximately 1020 litres. Research shows a near 50/50 split of average water use between domestic boiled and ambient filtered water usage.

**The volume limit is 1750 litres.** Based on half the capacity of the filter in the softer water conditions, this assumes 50% of the water is used for cold drinking water only.

After these limits the reminder status bar will reach the bottom and the boiler will beep each time when you dispense hot water. This beep is to remind you to check the filter, therefore ensuring the quality of water is consistent and the boiler is protected from any scale build up.

We also operate an automated filter reminder scheme to suggest when the filter is likely to need a replacement. Our customer care team will call or email with a reminder when replacement is likely to be required.

Irrespective of your water quality or usage pattern we recommend that the filter is replaced at minimum every 6 months in areas of a hardness 9 degrees Clark or higher, and no later than 12 months in areas of a hardness 8 degrees Clark or lower.

If you don't know the hardness (GB Clark rating) of your water, test your unfiltered cold water, refer to your installer's guide, check your postcode on your water supplier's website or contact your service agent for more help.



The filter head should be replaced after 5 years of service.



You will find that once you have changed the filter a few times you will get a feel for your personal water hardness and filter replacement schedule, the need to check the filter will become less frequent and quicker.

Due to the unique PROBOIL filter formulation and technology, conventional hardness test strips or digital meters cannot accurately show if the ION media (boiler scale protection and hardness reduction media) within the filter has been exhausted.

The only way of judging if the ION media is exhausted and therefore your filter needs to be replaced is by following the subsequent steps:



Scan here to link  
to a video demonstration.

- 1) Press and hold the MENU and DOWN SCROLL button simultaneously.
- 2) You should see a similar information screen to this example:

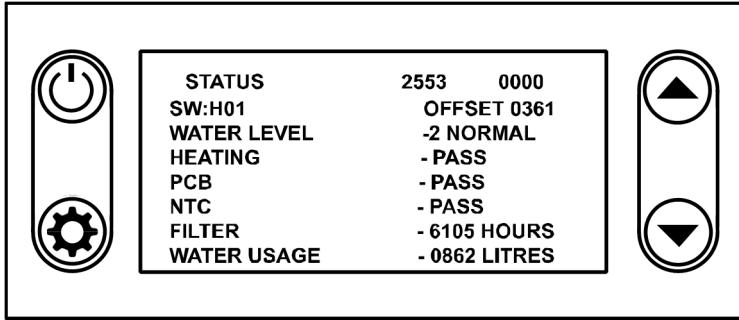

- 3) Take note of the “WATER USAGE” value then press the POWER button to return from this menu.

- 4) Take your GB Clark hardness value and add 2° (otherwise use the PPM hardness value and add 30PPM).

Now compare this **NEW HIGHER** Clark hardness value against the table in conjunction with the PROBOIL WATER USAGE value.

If the WATER USAGE figure is higher than the value \*REPLACE LITRES value in the table then filter will require replacing.

**Worked Example:** WATER USAGE = 0862 litres, your local water hardness is 11° Clark, add 2° Clark, then the ‘REPLACE LITRES’ value in the table for 13° Clark is 850 litres. In this example the ‘WATER USAGE’ is more than ‘REPLACE LITRES’ so the filter requires replacement.

Replacement filters can be obtained by contacting the service agent number on the sticker on the top of the boiler.

GB °Clark	PPM	*REPLACE LITRES
5	70	1960
6	90	1610
8	107	1415
9	125	1215
10	143	1065
11	161	945
13	179	850
14	196	775
15	214	640
16	232	590
18	250	545
19	268	510
20	286	480
21	304	450
24	339	405
26	375	365
29	411	335
33	464	250
36	518	220
41	589	185
48	679	170

If the filter does not need replacing (for instance you have installed the product in a soft water supply area), you can reset the filter reminder beep & indicator bar by pressing and holding both the up (▲) and down (▼) buttons together.

**IMPORTANT:** before you reset the filter counter you must keep a written note of the WATER USAGE value for when you next check your filter. When you come to recheck the WATER USAGE you must add the ‘new’ and ‘previous’ WATER usage totals together and use the combined total against the chart.

Whilst you get used to your likely personal filter replacement schedule, we recommend re-checking filter life frequently to protect the PROBOIL from scale.



## Replacing the filter:

Once you have decided that the filter needs replacing, you can order a replacement from the service contact details shown on the front of the boiler. When replacing the filter, have a dry cloth to hand for any small drips.

- 1) Turn on the cold filtered water by pushing the tap handle backwards.
- 2) Turn the blue lever found on the three way tee (E4) to the off position.
- 3) The flow rate of the filtered water coming from the tap should gradually decrease, before stopping completely.
- 4) Turn the filter (C5) anticlockwise (from right to left).
- 5) Pull the filter (C5) downwards away from the filter head (C3).
- 6) Unpack the new filter and check for any transport damage, write the replacement date on the filter label and remove the blue plastic dust cap from the top of the filter.
- 7) Insert the filter cartridge (C5) upwards into the filter head (C3). Note the filter label must face forward when fitted.
- 8) Turn the filter cartridge (C5) clockwise (left to right) to secure the filter cartridge (C5) to the filter head (C3).
- 9) Turn the blue lever found on the three way tee (E4) to the on position. Once the trapped air has cleared, cold filtered water will come from the tap. The water might at first be discoloured, but this is normal and will clear with flushing.
- 10) With a kitchen measuring jug and a clock you must:
  - a. Flush at least the first 5 litres of water away.
  - b. \*Adjust the blue lever on the three way tee (E4) so the flow rate of filtered water through the tap is 2 litres per minute (500 ml every 15 seconds or 1 pint every 17 seconds).
- 11) Once completed, turn off the cold filtered water tap, then check around the new filter and head for any leaks.
- 12) Finally reset the filter life indicator bar by pressing and holding both the up (▲) and down (▼) keys on the PROBOIL control for a few seconds. The filter indicator bar will refresh once complete.



Scan here to link  
to a video  
demonstration.

 We only warrant the original filter type supplied with your boiler, which is formulated specifically for the PROBOIL product. If the filter is removed or exchanged for an alternate model it may have a detrimental effect to your system and accordingly will invalidate your warranty. If you have specific or unusual incoming water conditions please contact the service number on the boiler for further advice.

 Failure to adjust the incoming water flow rate may reduce the filter life or prevent the filter from performing correctly, leading to premature damage to other components of the system and will therefore invalidate your warranty.

## Cleaning your mixer tap and boiler:

 Do not use **any** proprietary household domestic cleaning product on either the mixer tap or the boiler.

The mixer tap and Hotkey should only be cleaned regularly with mild dish soap, warm water and a non-abrasive cloth. Once the tap is clean, please ensure you rinse with warm water before drying thoroughly to prevent water marks.

If the tap has limescale marks it can be cleaned with a 50/50 mix of white vinegar and water and an old toothbrush. You should then rinse with warm water and then dry off the tap, again to prevent water marks reappearing as the water evaporates.

Where the tap has a removable aerator on the spout exit, it can be removed and cleaned periodically to maintain optimum flow performance. If the flow rate is noticeably slower than normal, or the water stream is spraying or shaped incorrectly, it is probably due to the aerator in need of a clean.

The aerator (found at the end of the spout) can be unscrewed. The plastic insert can now be descaled, rinsed and then reinserted in the reverse order.

The PROBOIL boiler unit should require no regular cleaning externally other than with a small amount of mild dish soap, water and a non-abrasive cloth. Once cleaned, dry off the unit thoroughly. Do not make the cloth any more than damp whilst wiping the unit.

## Troubleshooting & maintenance:



Servicing and maintenance of this product must be carried out by persons having knowledge and practical experience of the appliance, in particular as far as safety and hygiene are concerned. The PROBOIL system contains no user serviceable parts and should only ever be serviced by the recommended service agent.

With regular filter replacements and scheduled maintenance, this product will offer you good service. Like any product, it contains working parts that may require service or replacement. Below is a simple troubleshooting guide for both the boiler and mixer tap.

If you have any doubts about the nature of any issue that you may experience then please turn off the power to the boiler and contact the service agent. Contact details are listed on the top of the boiler.

### PROBOIL on screen messages:

Screen message:	Likely fault(s):	Action to take:
<b>Temperature Sensor:</b> Please turn off appliance at plug. See silver front plate for service contact details.	Faulty temperature sensor on tank.	Turn off the boiler. This is not a user serviceable part. Please contact the service number on the silver plate on the front of the boiler. You will need the model and serial number on the plate also.
<b>Not Heating:</b> Please turn off appliance at plug. See silver front plate for service contact details.	Various possible faults.	
<b>No Water:</b> Please turn off appliance at plug. See silver front plate for service contact details.	The water supply to the boiler is turned off.  The water pressure is low.  The inlet filter is blocked with debris. Electrical sensor fault.	<b>Does cold filtered still water come from the tap when turned on?</b> <b>No:</b> Check the water supply is turned on and the filter is not blocked. <b>Yes:</b> Turn off the boiler. Not a user serviceable part. Please contact the service number on the silver plate on the front of the boiler. You will need the model and serial number on the plate also.
<b>PCB Error:</b> Please turn off appliance at plug. See silver front plate for service contact details.	PCB has self-diagnosed a fault.	Turn off the boiler. This is not a user serviceable part. Please contact the service number on the silver plate on the front of the boiler. You will need the model and serial number on the plate also.
<b>Descale Required:</b> Your warranty is at risk. See silver front plate for service contact details.	The top level probe is calcified (scaled).	Turn off the boiler. Please contact the service number on the silver plate on the front of the boiler and obtain a descale kit and new filter. If this does not clear the error, please contact our service team again.
<b>Descale Shutdown:</b> Your warranty is at risk. See silver front plate for service contact details.	The top level and safety level probe is calcified (scaled).	
<b>Check Filter Reminder:</b> Your warranty is at risk. See silver front plate for service contact details.	The estimated filter life has been reached.	Check the filter condition. See <a href="#">“does my filter need replacing?”</a> section of this manual for more information.

**PROBOIL & mixertap troubleshooting tips:**

<b>Proboil Issue:</b>	<b>Likely fault(s):</b>	<b>Action to take:</b>
No display visible.	Power off. Fuse blown.	Check the power and any fuses/ Check the fuses are 13A. Hold the power key to turn on the boiler.
Odour from drain.	Vent connection tee incorrectly added after sink trap.	The vent tee (B2) must be on the sink side of any trap - remove and reposition.
	Odour from washer / dishwasher before the trap.	Run a cleaning program on the washer / dishwasher.
Excess water in vent and tundish. Water takes longer than usual to re-boil.	Boiler components are calcified.	Contact the service agent for a descaling kit, then follow the descaling guide.
Water drips from the drain hose.	Drain hose valve faulty.	Ensure the drain hose valve is fully turned off. If this does not resolve the issue, isolate the water and power to the PROBOIL, drain the system and contact the service agent.
The boiler is beeping each time I use the tap.	The filter reminder has activated.	This is normal please refer to. <a href="#">Does my filter need replacing?</a>

<b>Mixertap Issue:</b>	<b>Likely fault(s):</b>	<b>Action to take:</b>
Slow domestic hot water flow.	Aerator is blocked or partially blocked due to debris or scale.	Remove aerator - clean and replace. (see cleaning section of user guide)
	Domestic hot water pressure is from a gravity fed system and is lower than the stated recommended minimum.	Add a booster pump to the hot water cylinder to improve hot water flow.
Mixed water temperature is too cool.	Water pressures are unbalanced, hot water pressure is less than cold.	Reduce the pressure or flow of unfiltered cold water to the tap to nearer balance the pressures.
	Domestic hot water temperature is too low.	Increase the boiler output temperature to help compensate.
Water is spraying from the spout end.	Aerator is blocked or partially blocked due to debris or scale.	Remove aerator - clean and replace. (see cleaning section of user guide).
Water dripping from centre channel on the spout when not in use.	Flexible hose from tap to boiler does not have a constant fall back to the boiler.	Check the flexible hose is not looped, kinked and has a constant fall to the boiler.
Water dripping from outside channel on the spout when not in use.	If the water does not constantly drip, this is water remaining in the spout releasing under gravity.	None - this is normal.
	If the water does constantly drip the tap valves most likely need replacing.	Contact the service agent for replacement valves.
Water leaking between the tap body and the spout.	Damaged or worn spout O-rings.	Contact the service agent for replacement spout O-rings.
No heated water is dispensed when the Hotkey is placed near the tap.	The data wire connecting the tap to the boiler is disconnected.	Follow the wire from the tap to boiler. Check the plugs are firmly connected.
	The data wire connecting the tap to the boiler is damaged.	The wire to or from the boiler needs replacing. Contact the service agent for parts.
	The boiler is not switched on.	Check the boiler has power and the display is not showing any error messages.
	The boiler is not heating to the requested temperature.	Wait for the boiler to fill and heat until a constant 'READY' message is displayed.
The entire tap moves when used.	The tap fixing nut is loose and or gaskets from the fixing kit have been missed out of the assembly.	Check all the gaskets listed in the tap instructions are present. The tap is relocated centrally, then tightened fully using a basin wrench or box spanner.

## Taste & clarity issues:

Taste can be a very subjective topic. Below are some of the common questions relating to filtered water. The near boiling filtered water has its own separate channel within the mixer tap, whilst the unfiltered cold, filtered cold and hot water share a pathway. When comparing the taste of filtered and unfiltered water always taste the filtered water first.

When the PROBOIL system is newly installed, you might expect some taste issues but these should pass with flushing or a short period of normal use. If the taste persists, please contact your service agent.

 The majority of taste issues are resolved by flushing the tap for longer before use.

<b>Taste issue:</b>	<b>Likely Cause:</b>	<b>Solution:</b>
Taste of chlorine in filtered water.	The level of chlorination in your water supply is unusually high.	None.
	The filter cartridge is exhausted and needs replacing.	Replace filter cartridge.
	The cold filtered water is mixed with unfiltered cold water.	Flush the tap for longer before use.
Filtered water tastes metallic.	The filter is correctly removing the taste of the chlorine from the water, chlorine usually masks any such naturally occurring tastes in the water.	Flush the tap for longer before use, if the taste persists it is most likely as described.
Water is cloudy.	Air in the water.	You can check for air in the water by dispensing 2 glasses of water, one filtered and one normal cold water. In both cases it is normal for the water to be cloudy at first, before settling after approx. 10 minutes. However, if the cause is air then the glass will normally clear from the bottom upwards as the air rises.
	Chalk deposits in water.	In some water regions, cloudiness can also be attributed to chalk in the water. We recommend conducting the same test as above (air). However, this can take up to 1 hour to clear and in this case will clear from the top of the glass downwards as the debris settles.
	Loose carbon fines in the water.	Flush the tap for longer before use.
Acidic taste.	If the boiler has been descaled recently, some concentration of the descaling solution may remain in the tank.	Follow the section " <a href="#">draining the boiler</a> " to drain and refill the boiler. Repeat until the taste dissipates.
	The bypass setting on the filter head may have been set correctly.	Refer to installation section " <a href="#">filter installation</a> " and check the filter head bypass setting.
TCP / disinfectant taste.	Plastic or rubber components in the water supply reacting with chlorine.	Check that any additional plumbing work locally to the new mixer tap uses only WRAS approved materials.

## Proboil Warranty terms and conditions:

If you believe your product has developed a fault firstly isolate the product from the mains power and water then please contact the service agent (details shown on the top of the boiler), do not wait to do this once you suspect a fault, please have the model and serial numbers to hand when calling.

Your PROBOIL system is guaranteed against defective materials and workmanship for 2 years after installation provided the installation is registered, the system has been installed domestically and used strictly in accordance with the instructions supplied, that any failure is not due to accident, misuse, abuse, unsuitable water conditions, failure to service or maintain, alteration, modification or repair by any party not expressly nominated by the manufacturer.

Where any additional service or maintenance contract is subscribed to and is valid then these terms and conditions may be superseded and or improved, you should check for any appropriate additional cover that it may offer to these standard terms.

The manufacturer may, where appropriate, provide replacement parts for your product or repair or replace all or part of your product at their discretion under this warranty. Any associated or ancillary costs to be incurred by you as a result of replacement of the product or parts under this guarantee must in all cases be previously approved by manufacturer. This guarantee is in addition to and does not affect your statutory rights.

No warranty applies to the filter cartridge life, this is effected by the setup, varying water quality and personal pattern of usage and as such the combination of these variables is untestable. The information provided on filter life is from independent laboratory testing and as such is provided in good faith. Any product warranty is voided if the recommended filter cartridge, testing strips or descaling solution are not used, if the filter is setup incorrectly or not replaced as required accordingly to your personal water conditions in order to protect the PROBOIL working life and efficiency. No warranty applies to wear and tear expected to occur during the normal course of use, including without limitation, cosmetic rust, scratches, dents or comparable and reasonably expected losses or damages.

These installation guidelines have been prepared for your direction and you must exercise due care at all times, We do not accept responsibility for problems that may occur through improper installation. Whilst assembling the product take care not to accidentally loosen any screwed or fixed assemblies.

Once the installation is completed as instructed the installer should check carefully for any leaks, periodically you should visually check for any slower leaks also for prudence, if this is impractical due to the nature of the usage or property occupation we suggesting installing a standard market leak preventer.

Please ensure that your product is fitted in accordance with Local Water Byelaws.

Your warranty terms for the mixertap are shown in the tap installation and user guide.

Errors and omissions excepted, Should you find any errors in this guide please inform us to help continually improve any future revisions of our literature.

## Product Specifications:

### Mixer Tap:

<b>Functionality</b>	4 way mixer tap: Cold (unfiltered) water* Cold (filtered) water* Hot (domestic) water* Hot (80-98°C) water *via a common pathway	
<b>Safety features</b>	<ol style="list-style-type: none"> <li>1) Water temperature limited to a maximum of 98°C</li> <li>2) Removable child safe 'Hotkey' to dispense hot water</li> <li>3) Thermally insulated exterior surface</li> <li>4) Constant flow rate of hot water, reduced spitting &amp; steaming in use</li> </ol>	
<b>Min. domestic hot water pressure</b>	Varies by model, refer to tap installation instructions	
<b>Min. cold water pressure required</b>	Varies by model, refer to tap installation instructions	
<b>Maximum water pressure</b>	5.5 bar	
<b>Spout rotation angle</b>	360° (freely rotating)	
<b>Tap hole diameter(s)</b>	35mm +/-1mm	
<b>Tap hole thickness</b>	0-40mm	
<b>Nominal mixed flow rate at 3 bar</b>	Varies by model, refer to tap specifications	Note: inlet flow limiters are available separately to flow limit the tap if required to meet varying building standards.
For further detailed information refer to the tap specification for the model in question.		

### Boiler:

<b>Exterior dimensions</b>	175mm (w) x 400mm (d) x 410mm (h)
<b>Product weight</b>	Apx. 8 kg (when empty) / 12.5 (when filled)
<b>Power usage (standby mode)</b>	During standby: < 1W
<b>Heat up time (minutes)</b>	+10 °C to +99 °C: in approx. 15 min
<b>Supply Voltage Range</b>	220-240V
<b>Power (W) @ 230V</b>	2760W
<b>Frequency (Hz)</b>	50Hz
<b>Minimum cold water pressure required</b>	2.0 bar
<b>Maximum cold water pressure</b>	8 bar
<b>Maximum chlorine value</b>	100mg/l
<b>Tank material</b>	304 stainless steel
<b>Tank draw off volume</b>	Maximum single continuous draw off is 3.5 litres
<b>Recovery rate</b>	Maximum of 13.5 litres (47 cups) per hour at 98°C
<b>Temperature variability</b>	80-98°C (in tank temperature)
<b>Safety vent devices</b>	Vent and tundish supplied in line with Part G building regulations
<b>Boiler type</b>	Vented (unpressurised) pumped system
<b>Ambient operating temperature</b>	+5°C to +40°C (indoor use only)

Filter cartridge:

<b>Physical dimensions</b>	Filter only: 95Ø x 245mm Filter and head: 100Ø x 315mm
<b>Filter weight</b>	When empty: 0.96kg
<b>Minimum cold water pressure required</b>	2.0 bar
<b>Maximum cold water pressure</b>	8 bar
<b>Filter mesh rating</b>	5 micron nominal rating
<b>Primary filter contents</b>	Activated carbon block Ion selective media
<b>Capacity (activated carbon)</b>	1700 litres approximately, varies by location.
<b>Capacity (hardness reduction)</b>	Varies by location and use, see user guide for further details.
<b>Ambient incoming water temperature</b>	4-30°C
<b>Min. domestic hot water pressure</b>	Varies by model, refer to tap installation instructions

Parts and contents:

 This drawing shows the boiler and filter system parts. The 'Key' code will be referred to throughout the manual.

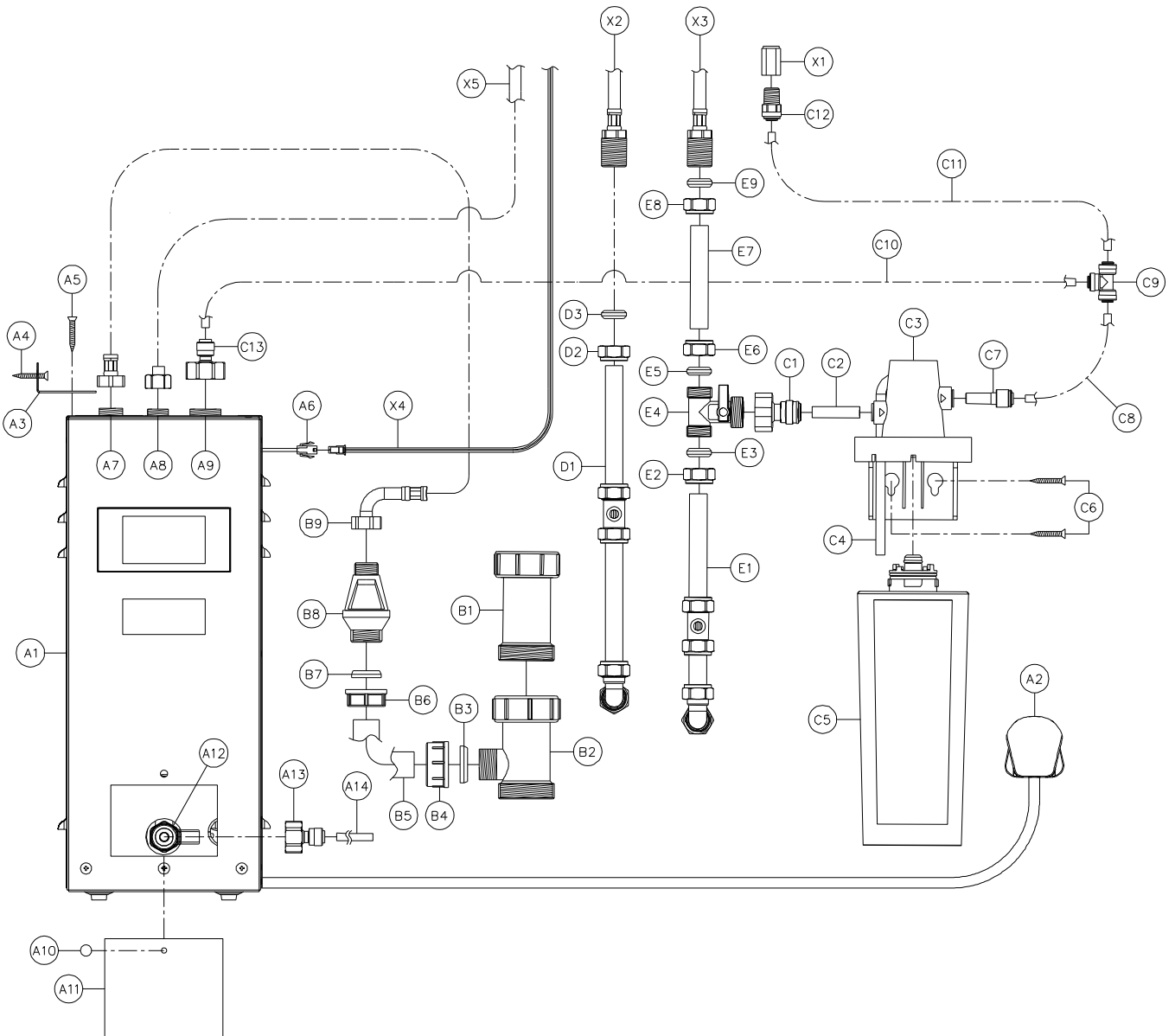



## Certification and Regulations:

### European Directives:

As a producer and a supplier of appliances we are committed to the protection of the environment and are in the compliance with the WEEE directive. All our electric products are labelled accordingly with the crossed out wheeled bin symbol. This indicates, for disposal purposes at end of life that these products must be taken to a recognised collection points, such as local authority sites/local recycling centres.

This appliance Complies with European Community Directives (CE) for household and similar electrical appliances and Gas appliances where applicable.

The following standards have been observed in relation to this product:

Standard	Details	Comments
WRAS	Water Regulations Advisory Service	All materials WRAS compliant with the exception of the pump which complies to NSF.
Part G building regulations	Hot water safety	All safety and discharge devices supplied as standard with product, product can be flow limited to meet any required level.
Ecodesign Directive (2009/125/EC)	Energy usage	This appliance conforms to European Directive 2009/125/EC regarding Eco design requirements for energy-related products. Water heaters used for making drinks are exempt.
BS EN 60335-2-75:2004 +A2:2008	Household and similar electrical appliances. Safety	
LVD (2014/35/EU)	Low voltage directive	
EMC (2014/30/EU)	Electromagnetic compatibility directive	
CE (93/68/EEC)	CE marking directive	
RoHS(2011/65/EU)	Restrictions of hazardous substances	
WEEE	Waste electrical and electronic equipment directive	Registration No. WEE/DK005977



At end of unit life, dispose of appliance and any replacement parts in a safe manner, via a licenced waste handler. Units are designed to be dismantled easily and recycling of all material is encouraged whenever practicable.